

Department of Engineering
Tim Bryan, P.E., County Engineer

3137 South Liberty Street, Canton, MS 39046
Office (601) 790-2520 FAX (601) 859-3430

MEMORANDUM

October 16, 2019

To: Sheila Jones, Supervisor, District I
Trey Baxter, Supervisor, District II
Gerald Steen, Supervisor, District III
David Bishop, Supervisor, District IV
Paul Griffin, Supervisor, District V

From: Tim Bryan, P.E.
County Engineer

Re: Woodscape of Oakfield, Phase 2
Final Plat

The Engineering Department recommends the approval of Woodscape of Oakfield, Phase 2 final plat. The development is approximately 16.5 acres with 51 lots. The Letter of Credit has been received for the final lift of asphalt.

WOODSCAPE OF OAKFIELD, PHASE 2

SITUATED IN THE SOUTH 1/2 OF SECTION 26, T8N-R2E,
MADISON COUNTY, MISSISSIPPI

Class "B" Survey
Bearings Based on Solar
Observation Taken On
April 14, 2016
Our Job No. M-2403-1
Date of Survey: September 18, 2019
Date of Plot: October 15, 2019
Scale: 1"= 100'
POB - Point of Beginning
POC - Point of Commencement
● Iron Pin (1/2"x18" Iron Rebar)
--- Easement Boundary
○ Minimum Finished Floor Elevation

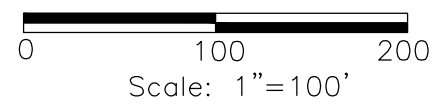
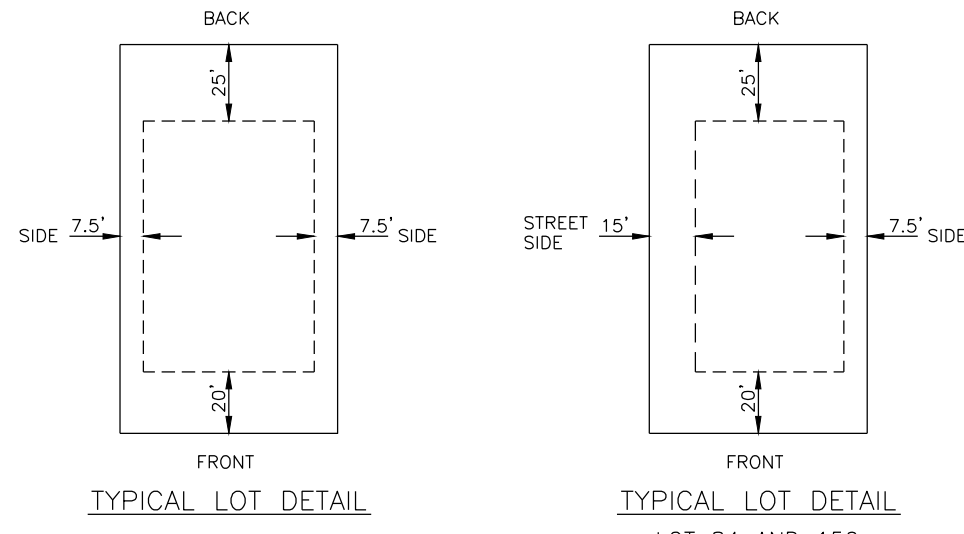
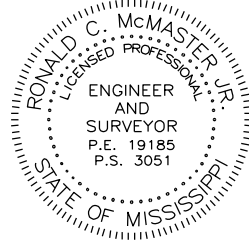

FIRE HYDRANT
ELEVATION TABLE

FH NO.	Top Nut Elevation
FH-1	284.96'
FH-2	287.31'
FH-3	277.70'
FH-4	281.19'
FH-5	283.76'

Curve Table

Curve #	Length	Radius	Chord Direction	Chord Length
C1	60.14	1960.00	S73° 49' 50"W	60.14
C2	56.46	1840.00	S73° 49' 50"W	56.45
C3	72.32	1960.00	S75° 46' 00"W	72.31
C4	67.89	1840.00	S75° 46' 00"W	67.89
C5	72.32	1960.00	S77° 52' 50"W	72.31
C6	67.89	1840.00	S77° 52' 50"W	67.89
C7	72.32	1960.00	S79° 59' 41"W	72.31
C8	67.89	1840.00	S79° 59' 41"W	67.89
C9	135.51	1790.00	S78° 40' 33"W	135.48
C10	31.92	20.00	S30° 46' 43"W	28.64
C11	38.81	425.00	N12° 20' 02"W	38.80
C12	60.36	425.00	N5° 38' 57"W	60.31
C13	21.45	975.00	S2° 12' 39"E	21.45
C14	65.11	975.00	S4° 45' 15"E	65.10
C15	29.28	975.00	S7° 31' 40"E	29.28
C16	58.81	175.00	N1° 14' 22"E	58.53
C17	25.82	175.00	N15° 05' 34"E	25.79
C18	26.44	20.00	S18° 32' 56"E	24.55
C19	22.74	50.00	N43° 23' 09"W	22.55
C20	57.39	50.00	N2° 31' 45"E	54.29
C21	46.69	50.00	N62° 09' 48"E	45.01
C22	41.82	50.00	S67° 07' 33"E	40.61
C23	26.44	20.00	N81° 01' 59"W	24.55
C24	3.63	175.00	N61° 41' 37"E	3.63
C25	68.38	175.00	N73° 28' 58"E	67.95
C26	19.76	175.00	N87° 54' 44"E	19.75
C27	31.22	4975.00	N89° 01' 58"W	31.22
C28	31.21	4975.00	N89° 23' 32"W	31.21
C29	47.21	5025.00	N89° 18' 10"W	47.21
C30	15.85	5025.00	N88° 56' 36"W	15.85
C31	102.78	125.00	N67° 35' 33"E	99.91
C32	114.38	125.00	N17° 49' 30"E	110.43
C33	25.19	1025.00	S7° 41' 02"E	25.19
C34	65.14	1025.00	S5° 09' 33"E	65.13
C35	31.45	1025.00	S2° 27' 35"E	31.45
C36	35.14	375.00	N4° 15' 54"W	35.13
C37	52.36	375.00	N10° 56' 59"W	52.32
C38	31.92	20.00	N60° 40' 41"W	28.64
C39	20.05	1790.00	S73° 16' 21"W	20.05

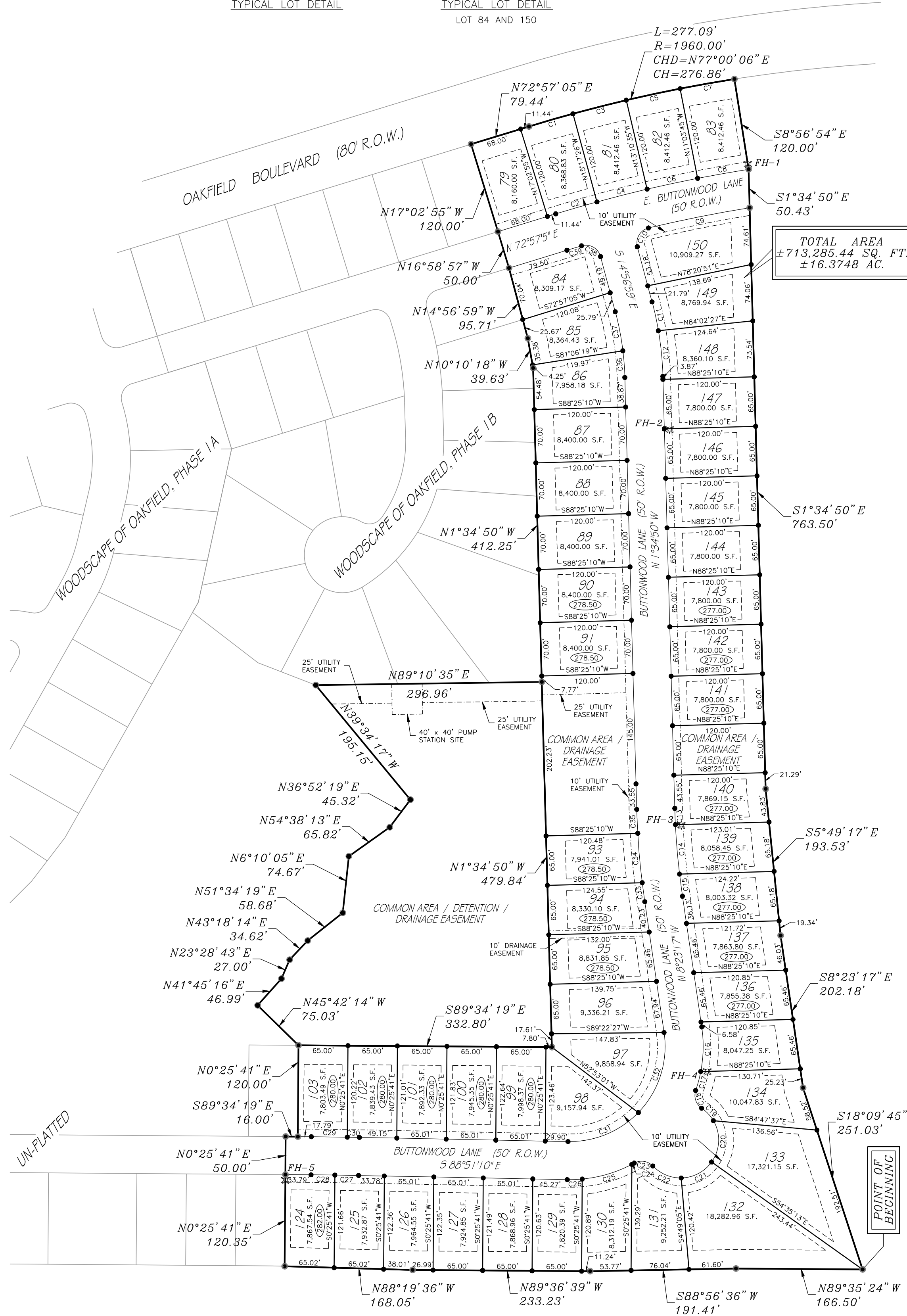
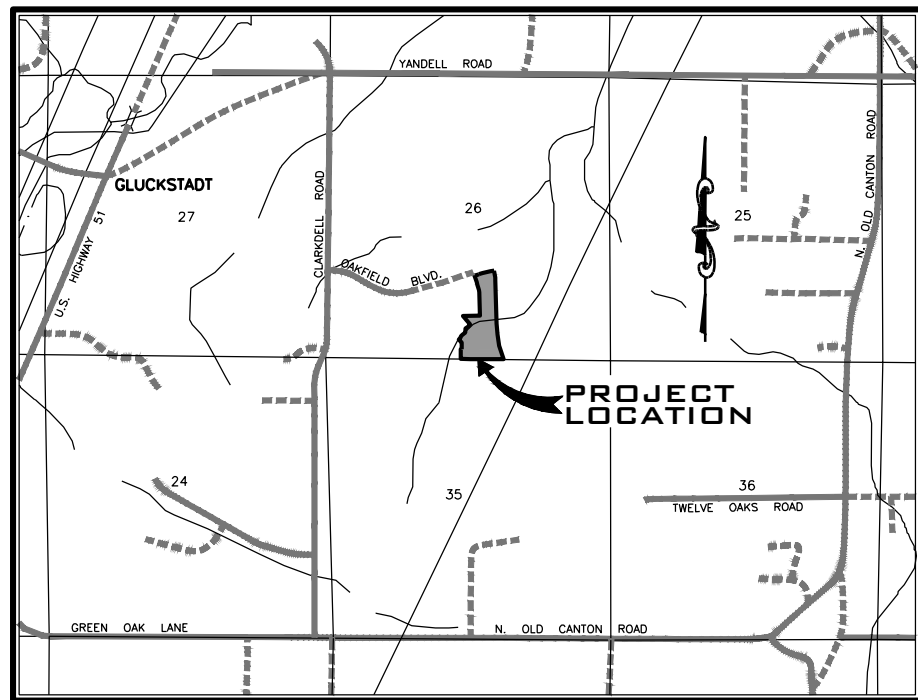

212 WATERFORD SQUARE
SUITE 300
MADISON, MS 39110
601.605.1090

WOODSCAPE OF OAKFIELD, PHASE 2

SITUATED IN THE SOUTH 1/2 OF SECTION 26, T8N-R2E,
MADISON COUNTY, MISSISSIPPI

SURVEYORS CERTIFICATE

STATE OF MISSISSIPPI
COUNTY OF MADISON

I, Ronald C. McMaster, Jr., Professional Engineer and Surveyor in the State of Mississippi, do hereby certify that at the request of Stillhouse Creek, LLC, the developer, have subdivided and

A parcel or tract of land, containing 16.3748 acres (713,285.44 Sq. Ft.), more or less, lying and being situated in the South 1/2 of Section 26, T8N-R2E, Madison County, Mississippi, being a part of the Oakhurst Development, Inc. property as described in Deed Book 3221 at Page 446 of the Records of the Office of the Chancery Clerk of said Madison County, at Canton, Mississippi, and being more particularly described as follows:

COMMENCING at a found iron rod lying at the SE corner of Section 26, T8N-R2E, Madison County, Mississippi, said point also being and lying at the SE corner of the above referenced Oakhurst Development, Inc. property; run thence

Along the Southerly boundary of said Oakhurst Development, Inc. property to iron pins at each of the following calls:

North 89 degrees 35 minutes 04 seconds West for a distance of 87.32 feet; thence
North 82 degrees 44 minutes 35 seconds West for a distance of 10.88 feet; thence
North 88 degrees 46 minutes 37 seconds West for a distance of 139.27 feet; thence
South 89 degrees 25 minutes 08 seconds West for a distance of 187.31 feet; thence
South 88 degrees 51 minutes 03 seconds West for a distance of 506.59 feet; thence
South 89 degrees 10 minutes 22 seconds West for a distance of 261.57 feet; thence
North 89 degrees 44 minutes 11 seconds West for a distance of 459.65 feet; thence
North 88 degrees 09 minutes 49 seconds West for a distance of 115.46 feet; thence
North 89 degrees 15 minutes 34 seconds West for a distance of 162.48 feet; thence
North 89 degrees 35 minutes 24 seconds West for a distance of 68.36 feet to the POINT OF BEGINNING of the herein described property; thence
Continue North 89 degrees 35 minutes 24 seconds West for a distance of 166.50 feet; thence
North 88 degrees 56 minutes 36 seconds West for a distance of 191.41 feet; thence
North 89 degrees 36 minutes 39 seconds West for a distance of 233.23 feet; thence
North 88 degrees 19 minutes 36 seconds West for a distance of 168.05 feet; thence

Leaving the Southerly boundary of said Oakhurst Development, Inc. property, run North 00 degrees 25 minutes 41 seconds East for a distance of 120.35 feet to an iron pin; thence

Continue, North 00 degrees 25 minutes 41 seconds East for a distance of 50.00 feet to an iron pin; thence
South 89 degrees 34 minutes 19 seconds East for a distance of 15.00 feet to an iron pin; thence
North 00 degrees 25 minutes 41 seconds East for a distance of 120.00 feet to an iron pin; thence
North 45 degrees 42 minutes 14 seconds West for a distance of 75.03 feet to an iron pin, said point lying on the East line of the Detention Area as shown on the Plat of Woodscape of Oakfield, Phase 1A, recorded in Plat Book Cabinet F, Slide 81A and 81B; thence

Along said East line of the Detention Area to iron pins at each of the following calls:

North 41 degrees 45 minutes 16 seconds East for a distance of 46.99 feet; thence
North 23 degrees 28 minutes 43 seconds East for a distance of 27.00 feet; thence
North 43 degrees 18 minutes 14 seconds East for a distance of 34.62 feet; thence
North 51 degrees 34 minutes 39 seconds East for a distance of 58.68 feet; thence
North 06 degrees 10 minutes 05 seconds East for a distance of 74.67 feet; thence
North 54 degrees 38 minutes 13 seconds East for a distance of 65.82 feet; thence
North 36 degrees 52 minutes 19 seconds East for a distance of 45.32 feet; thence
North 39 degrees 34 minutes 17 seconds West for a distance of 195.15 feet to the Southerly boundary of Woodscape of Oakfield, Phase 1B; thence

Along the Southerly and Easterly boundary of said Woodscape of Oakfield, Phase 1B to iron pins at each of the following calls:

North 89 degrees 10 minutes 35 seconds East for a distance of 296.96 feet; thence
North 01 degrees 34 minutes 50 seconds West for a distance of 412.25 feet; thence
North 10 degrees 10 minutes 18 seconds West for a distance of 39.63 feet; thence
North 14 degrees 56 minutes 59 seconds West for a distance of 95.71 feet; thence
North 16 degrees 58 minutes 57 seconds West for a distance of 50.00 feet; thence
North 17 degrees 02 minutes 55 seconds West for a distance of 120.00 feet to the NE corner, thereof, said point also lying on the Southerly Right-of-Way of proposed Oakfield Boulevard; thence

Along the Southerly Right-of-Way of proposed Oakfield Boulevard to iron pins at each of the following calls:

North 72 degrees 57 minutes 05 seconds East for a distance of 79.44 feet; thence

277.09 feet along the arc of a 1960.00 foot radius curve to the right, said arc having a 276.86 foot chord which bears North 77 degrees 00 minutes 06 seconds East; thence

Leaving the Southerly Right-of-Way of proposed Oakfield Boulevard, run to iron pins (points) at each of the following calls:

South 08 degrees 56 minutes 54 seconds East for a distance of 120.00 feet to a point; thence
South 01 degrees 34 minutes 50 seconds East for a distance of 50.43 feet to a point; thence
South 01 degrees 34 minutes 50 seconds East for a distance of 763.50 feet to a point; thence
South 05 degrees 49 minutes 17 seconds East for a distance of 193.53 feet to a point; thence
South 08 degrees 23 minutes 17 seconds East for a distance of 202.18 feet to a point; thence
South 18 degrees 09 minutes 45 seconds East for a distance of 251.03 feet to the POINT OF BEGINNING of the above described parcel or tract of land.

Witness my signature, this the _____ day of _____, 2019.

Ronald C. McMaster, Jr., Professional Engineer and Surveyor
Mississippi P.S. No. 3051

SURVEYOR'S CERTIFICATE OF COMPLIANCE

STATE OF MISSISSIPPI
COUNTY OF MADISON

I, Ronald C. McMaster, Jr., Professional Engineer and Surveyor, do hereby certify that the monuments and markers shown hereon are in place on the ground and the plat and plan shown and described hereon are a true and correct representation of a survey to the accuracy designated in the subdivision regulations for Madison County, Mississippi.

Witness my signature this the _____ day of _____, 2019.

Ronald C. McMaster, Jr., Professional Engineer and Surveyor

COUNTY ENGINEER'S RECOMMENDATION

STATE OF MISSISSIPPI
COUNTY OF MADISON

I have examined this plat and find it conforms to all conditions set forth on the preliminary plat as approved by the Board of Supervisors of Madison County, Mississippi and thus recommend final approval.

By: _____
Timothy Bryan, P.E.
Madison County Engineer

APPROVAL OF THE BOARD OF SUPERVISORS

STATE OF MISSISSIPPI
COUNTY OF MADISON

I hereby certify that this is a true copy and that this plat was approved by the Board of Supervisors of Madison County in session on the _____ day of _____, 2019.

Madison County Board of Supervisors

By: _____
Trey Baxter, President

Attest:

Ronny Lott, Chancery Clerk

CERTIFICATE OF COMPARISON

STATE OF MISSISSIPPI
COUNTY OF MADISON

We, Ronny Lott, Chancery Clerk and Ronald C. McMaster, Jr., Professional Engineer and Surveyor, do hereby certify that we have carefully compared this plat of WOODSCAPE OF OAKFIELD, PHASE 2 with the original thereof, as made by Ronald C. McMaster, Jr., Professional Engineer and Surveyor, and find it to be a true and correct copy of said map or plat.

Given under my hand and seal of office this the _____ day of _____, 2019.

Ronald C. McMaster, Jr., P.E., P.S.

Ronny Lott, Chancery Clerk

By: _____ D.C.

FILED AND RECORDATION

STATE OF MISSISSIPPI
COUNTY OF MADISON

I, Ronny Lott, Chancery Clerk in and for said County and State, do hereby certify that the final plat of WOODSCAPE OF OAKFIELD, PHASE 2 was filed for record in my office on this the _____ day of _____, 2019, and was duly recorded in Plat Cabinet _____ of the records of maps and plots of land in Madison County, Mississippi.

Given under my hand and seal of office this the _____ day of _____, 2019.

Ronny Lott, Chancery Clerk

By: _____ D.C.

CERTIFICATE AND DEDICATION OF OWNER

STATE OF MISSISSIPPI
COUNTY OF MADISON

I, J. Blake Cress, Manager of Stillhouse Creek, LLC, a Mississippi Limited Liability Company, do hereby certify that the aforementioned is the owner of the land described in the foregoing certificate of Ronald C. McMaster, Jr., Professional Engineer and Surveyor, and that as a Manager of said Stillhouse Creek, LLC, have caused the same to be subdivided and plotted as shown hereon, and hereby adopt this plat of subdivision as the free act and deed of said limited liability company and have designated the same as WOODSCAPE OF OAKFIELD, PHASE 2. All utilities, utility easements, and other easements are as designated and defined hereon. All utilities, utility easements, streets, and street rights-of-way shall be dedicated for public use.

Witness my signature this the _____ day of _____, 2019.

STILLHOUSE CREEK, LLC
A Mississippi Limited Liability Company

By:

J. Blake Cress, Manager

ACKNOWLEDGMENT

STATE OF MISSISSIPPI
COUNTY OF MADISON

Personally appeared before me, the undersigned officer in and for the jurisdiction aforesaid, the within named J. Blake Cress, Manager, who acknowledged to me that he is a Manager of Stillhouse Creek, LLC, a Mississippi Limited Liability Company, who acknowledged to me that he signed and delivered this plat and the certificates thereon, for and on behalf of said Stillhouse Creek, LLC, as its act and deed, after being authorized so to do, and Ronald C. McMaster, Jr., Professional Engineer and Surveyor, who acknowledged to me that he signed and delivered this plat and the certificates thereon as his own act and deed, on the day and year herein mentioned.

Given under my hand and seal of office this the _____ day of _____, 2019.

By: _____ D.C.

Ronny Lott, Chancery Clerk

NOTES:

- This is to certify that this property is located in Zone "X"-Other Areas, defined as "Areas determined to be outside the 0.2% annual chance floodplain" as shown on FIRM Map Number No. 28099C0415F, revised date of March 17, 2010.
- Iron pins at lot corners as shown on this plat. Field work meets or exceeds the requirements for a Class "B" survey.
- No fences or other obstructions may be placed in or otherwise block/interfere with the drainage easements shown.
- No building may be constructed within any drainage or utility easement shown hereon.
- The finish floor elevations shown represent the minimum elevation for the proposed structures, and should be adjusted higher to correspond with existing drainage patterns and surrounding grades. The minimum lot elevations for these lots shall be at or above the 100-year elevation.
- Damage caused to any infrastructure owned or maintained by Madison County resulting from work done by others including, but not limited to, the placing of utilities and fences shall be the financial responsibility of the owner of said work.
- Maintenance of all drainage easements and common areas are the responsibility of the Homeowner's Association.
- The individual lot owners/builders are responsible for additional drainage improvements (i.e. catch basins, storm pipe, french drains etc.) needed to facilitate water flow on or across their lot.
- There is a five (5) foot wide private drainage and utility easement along the sides and rear lines of each lot, unless otherwise noted.
- A relief swale shall be constructed down each lot line and shall be a minimum depth of 18" depth below the finished floor elevation of the home.
- All of the property within this subdivision is subject to the provisions of the covenants and restrictions for Oakfield Subdivision recorded in Book 2671 at Page 313 and Book 3697 at Page 136, together with any amendments or supplements thereto as may be declared by the Declarant and filed of record in the office of the Chancery Clerk of Madison County, Mississippi.

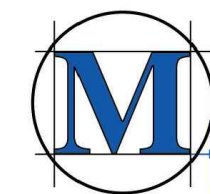
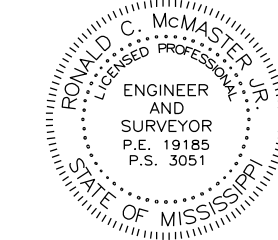
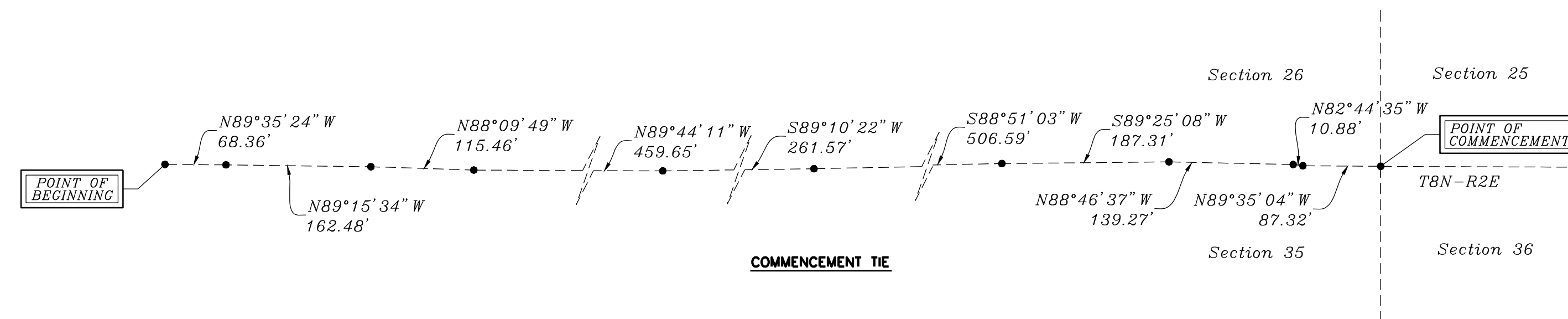

MCMASSTER & ASSOCIATES, INC.
CIVIL ENGINEERS & LAND SURVEYORS
212 WATERFORD SQUARE
SUITE 300
MADISON, MS 39110
601.695.1099